

# Maestro BAL Bushfire Rated Powered Roof Ventilator

Refer to product table below for applicable product codes covered by this document

Issue |

## Product Type & Application

Maestro BAL is a bushfire rated, smart roof ventilator with a low voltage electronic commutating motor fitted with temperature and humidity sensors to control fan operation and speed. It is specifically designed to meet the requirements of BAL12.5 to BAL40 for Class 1 and Class 10 buildings in non-cyclonic regions.

## Compliance with the NCC

When correctly specified and installed this powered roof ventilator:

### NCC2022

- **Ventilation of Roof Spaces** - Meets the requirements of ABCB Housing Provisions Standard 2022 10.8.3 via performance solution for condensation management for NCC Climate Zones 6, 7 and 8.
- **Construction in Bushfire Prone Areas** - Meets the requirements of NCC 2022 Volume 2 H7D4 through compliance with AS 3959.
- **Weatherproofing** - Meets the requirements of the NCC 2022 Volume 2 Weatherproofing Performance Requirement H2P2 via Deemed-to-Satisfy (DtS) and Performance Solution pathways.

### NCC 2019

- **Ventilation of Roof Spaces** - Meets the requirements of NCC 2019 Volume 2 Amend. 1 3.8.7.4 via performance solution.
- **Construction in Bushfire Prone Areas** - Meets the requirements of NCC 2019 Volume 2 Amend. 1 3.10.5 through compliance with AS 3959.
- **Weatherproofing** - Meets the requirements of the NCC 2019 Volume 2 Amend. 1 Weatherproofing Performance Requirement P2.2.2 via Deemed-to-Satisfy (DtS) and Performance Solution pathways.

## Evidence of Suitability

- Ventilation of roof spaces NCC 2022 –
  - Surex Performance Solution Report SUR22127.
- Ventilation of roof spaces NCC 2019 Amend. 1 –
  - Cardno Performance Solution Report 80820109.
- Construction in Bushfire Prone Areas –
  - CSIRO BAL Assessment Report FCO-3493.
- Weatherproofing –
  - Arcadis Report 30051677\_4.

## Limitations of Use

- **IMPORTANT** - Do Not Modify This Product: Compliance with the evidence of suitability data referenced in this document is only achieved by the product or configuration listed in this PTS.
- This product has not been tested for use in cyclonic wind regions C or D.
- Do not use for exhausting hazardous, abrasive, acidic and alkaline vapour or areas containing explosive or corrosive materials.
- This product is not suitable for BAL-FZ rated areas.

## Conditions of Storage, Use & Maintenance

- Store in the original packaging in a cool and dry area.
- The electronics and electrical components are for indoors installation only and should not come into contact with water.
- Do not attempt to repair – contact Bradford Ventilation for service advice.

Refer to the product warranty at [bradfordventilation.com.au](http://bradfordventilation.com.au) for more information.

## Specific Design or Installation Instructions

- Isolate power before installation.
- This product is suitable for use in residential Class 1 applications in BAL 12.5 to 40 zones when installed and sealed in accordance with the Maestro BAL installation guide.
- This product requires specific areas to be sealed against water entry and other areas to be left unsealed to allow internal condensation drainage – refer to the installation guide for details.
- This is a BAL-rated product and must be sealed in accordance with the Maestro BAL installation guide using a fire rated sealant that matches the BAL rating of the product - all gaps greater than 2mm must be sealed and materials used to seal the penetration must be non-combustible.
- The power supply and speed controller are for dry indoor use only. Ensure that the power supply and speed controller are not left on damp surfaces - fasten to the internal structure with screws or cable ties as required.
- Electrical connection requires 240VAC GPO for operation.
- Only use one powered ventilator per speed controller and power supply as supplied by Bradford Ventilation.
- Use only the default fixed speed (identified by a label on the product) to comply with NCC2019 Amend. 1 and NCC 2022 Ventilation of Roof Spaces Performance Solutions.

## Maestro BAL Bushfire Rated Powered Roof Ventilator

### Specific Design or Installation Instructions cont.

- Replacement outside air must be provided via evenly distributed openings such as Bradford Ventilation Metal Eave Vents positioned to facilitate cross-flow ventilation and help the powered ventilator to work more effectively and efficiently.
- This product contains a fan which might be audible when in operation – avoid positioning the product directly over bedrooms, bedroom ensuites or on a roof area adjacent to, or overlooked by an upper storey level of the home where the fan noise may be heard.

### NCC2022 Ventilation of Roof Spaces Performance Solution Requirements in Table 1:

The table below shows the powered ventilator and replacement air configurations necessary to meet the condensation management requirement in NCC Climate Zones 6, 7 and 8. The NCC stipulates an open area requirement per meter length of the longest horizontal dimension of the roof - the performance solution provided in Table 1 is an equivalent solution derived from the powered ventilator air-flow rates.

Maestro BAL powered ventilators should be installed not more than 900mm below the ridge or highest point of the roof space, measured vertically.

**Table 1. NCC 2022 Bradford Performance Solution Table for all roof pitches above 10°**

Longest Horizontal Roof Dimension	Number of Maestro BAL Ventilators Required <sup>1</sup>	Number of Bradford Metal Eave Vents Required	Unobstructed area for air replacement <sup>2</sup>
0 to <50m	1	4	0.15m <sup>2</sup>
50m to <100m	2	6	0.21m <sup>2</sup>

<sup>1</sup> At pre-fixed speed.

<sup>2</sup> The unobstructed area for air replacement is an alternate solution to replace Bradford Metal Eave Vents and assumes evenly distributed openings in accordance with the NCC requirement.

### NCC2019 Ventilation of Roof Spaces Performance Solution Requirements in Table 2:

- Calculate the area (m<sup>2</sup>) of ceiling directly under the roof space;
- Determine the pitch of the roof;
- Install Maestro BAL(s) and Metal Eave Vents according to the Bradford Ventilation Performance Solution Table;
- Distribute the powered ventilator(s) and metal eave vents evenly.

**Table 2. NCC 2019 Bradford Performance Solution**

Roof Pitch	Total Ceiling Area <sup>1</sup>	Maestro BALs Required <sup>2</sup>	Metal Eave Vents	Make-Up Air Open Area <sup>3</sup>
> 22°	< 203 m <sup>2</sup>	1	4	0.15 m <sup>2</sup>
	< 407 m <sup>2</sup>	2	6	0.21 m <sup>2</sup>
≤ 22°	< 127 m <sup>2</sup>	1	4	0.15 m <sup>2</sup>
	< 254 m <sup>2</sup>	2	6	0.21 m <sup>2</sup>
	< 381 m <sup>2</sup>	3	8	0.28 m <sup>2</sup>

<sup>1</sup> Total Ceiling Area is defined as the total ceiling area directly under the roof/attic space.

<sup>2</sup> At pre-fixed speed.

<sup>3</sup> The Make-Up Open Area air is an alternate solution to replace Bradford Metal Eave Vents and assumes evenly distributed openings in accordance with the NCC requirement.

**For general installation guidance refer to the product installation guide at [www.bradfordventilation.com.au](http://www.bradfordventilation.com.au)**

## Maestro BAL Bushfire Rated Powered Roof Ventilator

### Applicable Product Codes (SKU)

Variant	Material Code	Variant	Material Code
Maestro BAL - Headland	134207	Maestro BAL – Dover White	486252*
Maestro BAL – Night Sky	134205	Maestro BAL – Dune	153005*
Maestro BAL - Surfmist	134206	Maestro BAL – Ironstone	153006*
Maestro BAL – Woodland Grey	129247	Maestro BAL – Jasper	153004*
Maestro BAL – Monument	134208	Maestro BAL – Manor Red	134211*
Maestro BAL – Mill	153002*	Maestro BAL – Pale Eucalypt	134212*
Maestro BAL – Basalt	194441*	Maestro BAL – Paperbark	194554*
Maestro BAL – Bluegum	486250*	Maestro BAL – Shale Grey	134209*
Maestro BAL – Classic Cream	178821*	Maestro BAL – Southerly	486251*
Maestro BAL – Cottage Green	153008*	Maestro BAL – Windspray	153009*
Maestro BAL – Deep Ocean	194555*		

\*Available made to order with a longer manufacturing lead time.

### Product Specifications

General	
Ventilator Type	BAL Powered Ventilator
Fan Diameter	187 mm
Flashing Opening Diameter	300 mm
Minimum Throat Diameter (Not suitable for use in calculating NCC Ventilation opening requirements)	190 mm
NCC Ventilation Openings	NCC ventilation opening compliance requirements for Climate Zones 6, 7 and 8 are addressed by a Performance Solution, as detailed in the 'Compliance with the NCC' and 'Evidence of Suitability' sections above. The Performance Solution equates the NCC specified open area with a tested flow rate at a fixed speed for powered ventilators.
Product Weight	5.0 kg
Packaged Weight	5.9 kg
Roof Slope Installation Range	<b>Tiled Roofs</b> 15° to 35° <b>Metal Sheet Roofs</b> 3° to 35° Note: Where applicable all roof pitches must comply to AS1562.1, the NCC & Australian Standards weatherproofing requirements within the ranges above.

## Maestro BAL Bushfire Rated Powered Roof Ventilator

Electrical	
Power Supply Type	Electronic Switch Mode
Input Voltage	100-240VAC, 1.8A, ~50/60Hz
Output Voltage	24 VDC, 2.0A
Cable Length	Approx. 1.8 m
Installation Location	Indoor, Dry Area
Fan Type	Electronic Commutating Motor
Internal Voltage	24 VDC
Protection Class	IP54
Maximum Flow Rate	880 m <sup>3</sup> /hr

Material	
Dome	Aluminium
Housing	Aluminium
Flashing	Aluminium
Fan and Motor Housing	Die Cast Aluminium
Fan Impeller	Steel
Screws	Stainless Steel and Galvanised

### Product Performance – Ventilator Flowrate

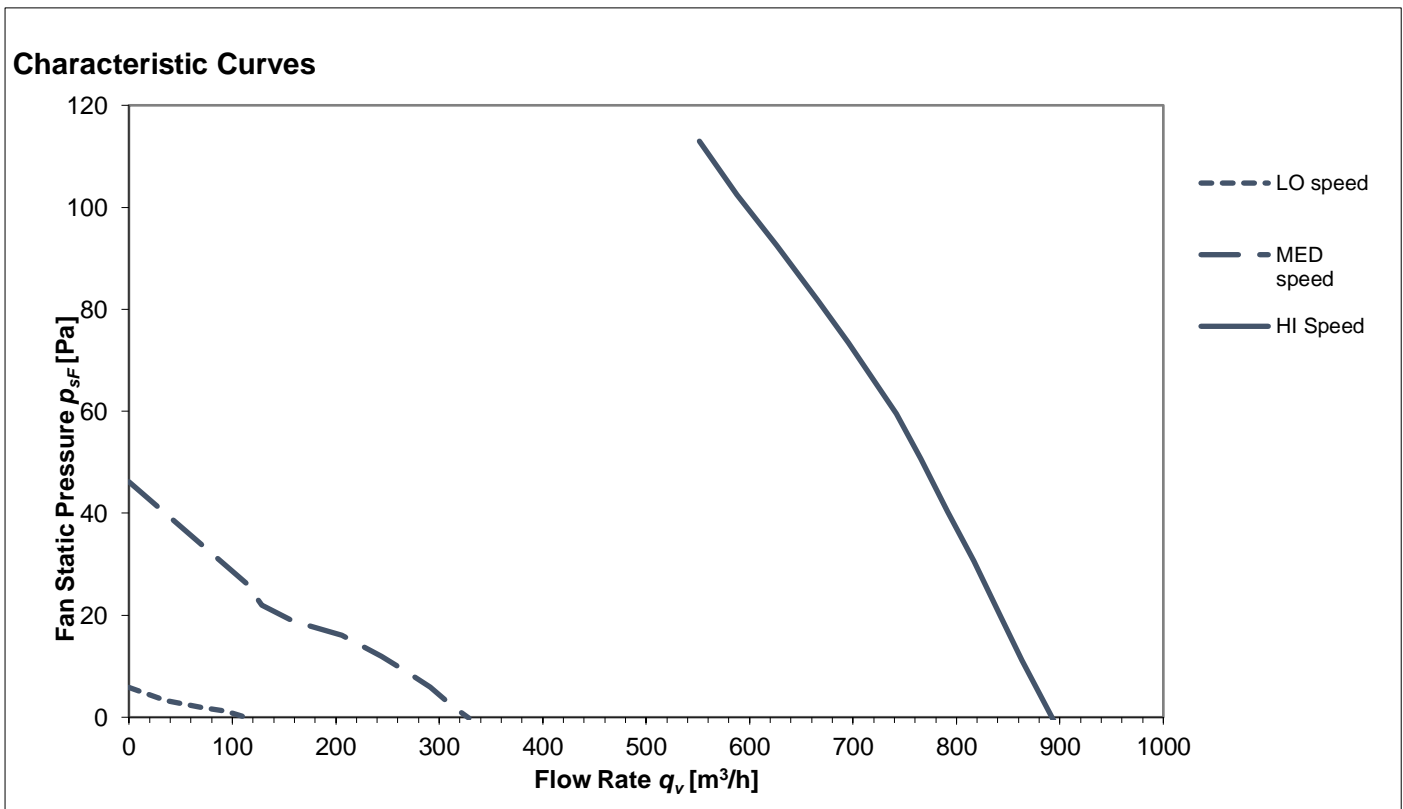

## Maestro BAL Bushfire Rated Powered Roof Ventilator

### Ventilator Fan Speed Option

Maestro BAL has 3 fixed speed options available (LO, MED, HI) or a variable (AUTO) speed which responds to both ambient temperature and to ambient relative humidity.

- In AUTO when measuring the temperature, the fan response will be off below 30°C, LO speed at 30°C and a linear increase in speed until HI speed is reached at 45°C.
- In AUTO when measuring relative humidity, the fan response will be off below 65%rH. At 65%rH the fan will start in LO speed and there will be a linear increase in speed until MED speed is reached at 80%rH.

The two charts below summarise the fan response.

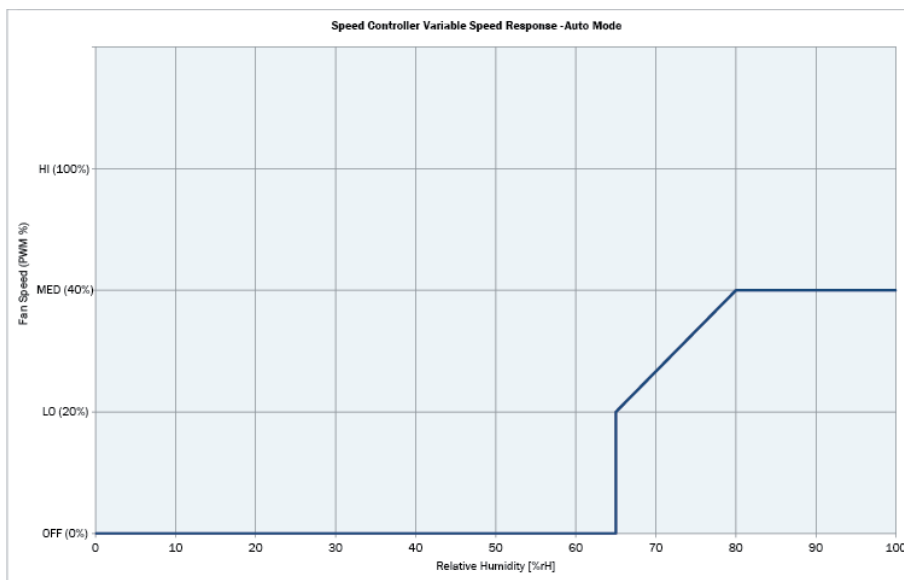
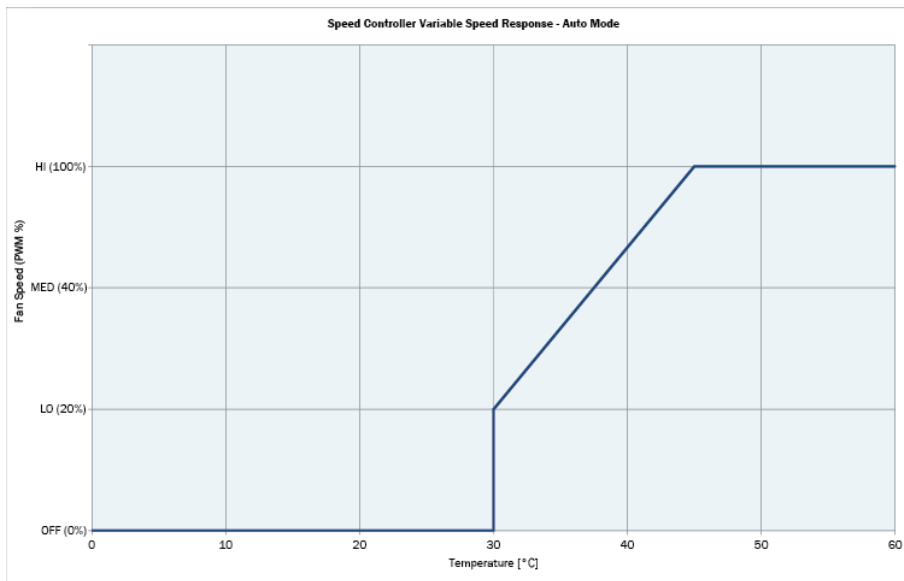

# Maestro BAL Bushfire Rated Powered Roof Ventilator

## Product Dimensions

Top View

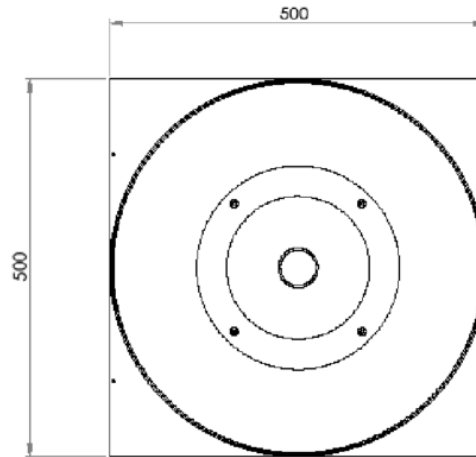

Front View

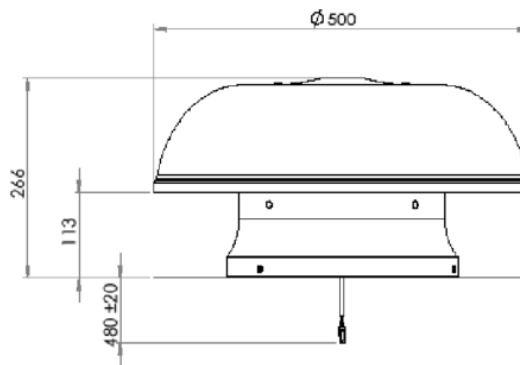

Speed Controller

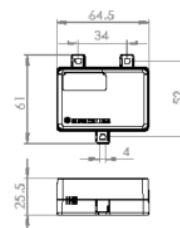

Power Supply

